

Heavy Duty Electrical Box Hanger

APPLICATIONS

FEATURES

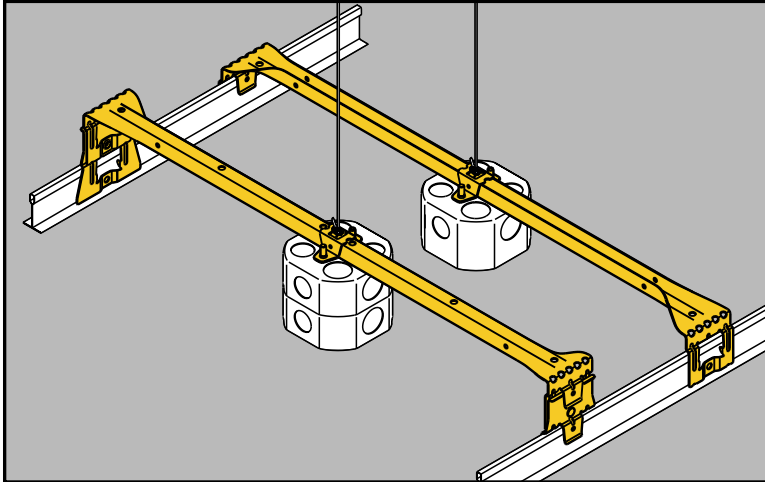

- Supports 4" or 4^{11/16}" octagonal or square boxes.
- Bendable ends enable mounting of 1^{1/2}" or 2^{1/8}" deep boxes in an instant. No tools or cutting is required to adjust bar.
- Self-centering feature positions box on center without measuring.
- Independent support wire can be attached for extra stability. Can be screwed to T-bar for fixing location.
- **Static Load Capacity:** 70 Lbs.
- Accessories available:
 - Box mounting clip for multiple box installation
 - Extender brackets for installation with 1^{1/2}" extension ring
 - Spacer shims for fine adjustment of box on unique applications

Acoustical Tee

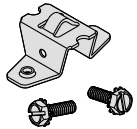
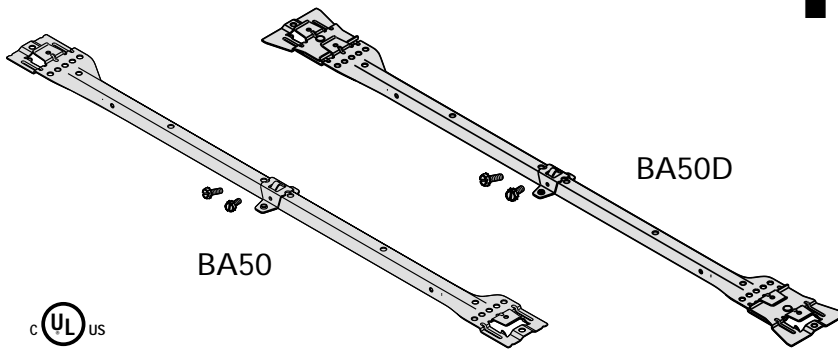

BA50C12

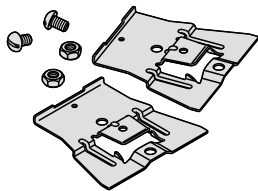

BA50E



BA50T

PART NUMBER	DESCRIPTION	UPC NO. 781011	BOX QTY.
BA50	Box Hanger for 1 ^{1/2} " or 2 ^{1/8} " deep boxes - 24" span	96490	25
BA50D	Box Hanger for 1 ^{1/2} " or 2 ^{1/8} " deep boxes with 1 ^{1/2} " extension ring - 24" span	96491	25
BA50C12	Box Mounting Clip with hardware	96488	25
BA50E	Extender Brackets with hardware (10 pair)	96489	20
BA50T	Spacer Shims	96565	50